

20 AMP, DOUBLE - POLE ELECTRO MECHANICAL SWITCH / BREAKER (3) PLACES

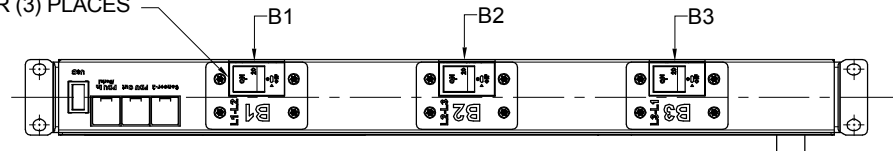

REAR VIEW

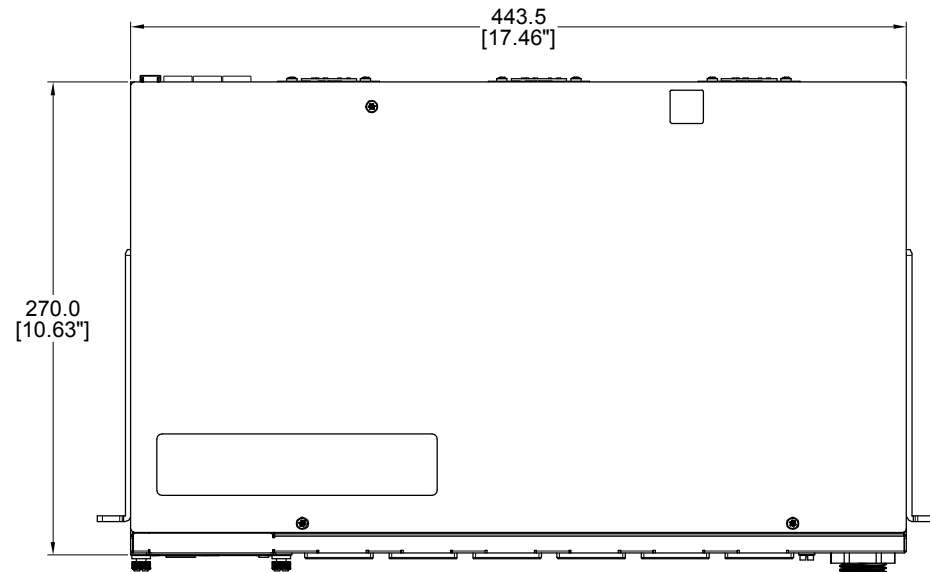

TOP VIEW

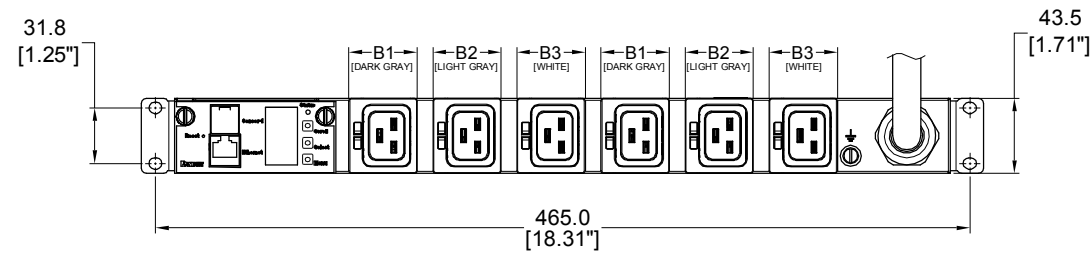

FRONT VIEW

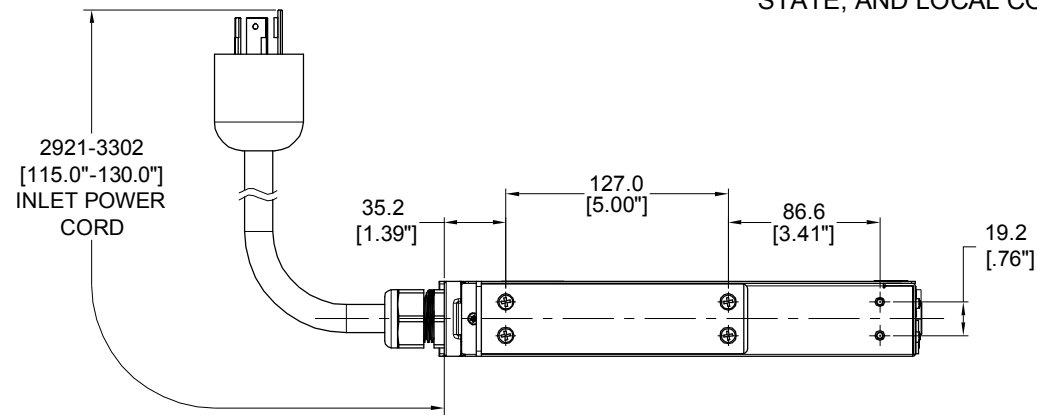

SIDE VIEW

PANDUIT P/N	WEIGHT
P06D16M	9.1kg

NOTES:

1. IDENTIFICATION:

UNIT TYPE: MONITORED INPUT
 ORIENTATION: HORIZONTAL, 1U
 OUTLET QTY&TYPE: (6)C19
 BREAKER QTY&TYPE: (3) 20AMP, DOUBLE-POLE
 INPUT VOLTAGE: 200-240VAC, DELTA
 INPUT CURRENT: 30A (24A DERATED)
 INPUT PHASE: THREE-PHASE DELTA
 RATED POWER: 8.6kVA
 INPUT PLUG: NEMA L15-30P
 INPUT CORD LENGTH: 3m [10']

2. ACCESSORIES:

POCKET GUIDE
 QTY: (4) M6 X 12 PAN HEAD MACHINE SCREWS
 QTY: (4) M6 CAGED NUT

3. RoHS COMPLIANT

4. VISIT PANDUIT'S ON-LINE CATALOG AT WWW.PANDUIT.COM FOR FOR ADDITIONAL PRODUCT INFORMATION CONTAINED IN THE SPECIFICATION SHEET AS WELL AS A CURRENT LIST OF PRODUCTS APPLICABLE FOR USE WITH THIS PART

5. MAXIMUM ALLOWABLE INPUT POWER = 8.6kW

6. INSTALLATION SHALL COMPLY WITH ALL APPLICABLE NATIONAL, STATE, AND LOCAL CODES

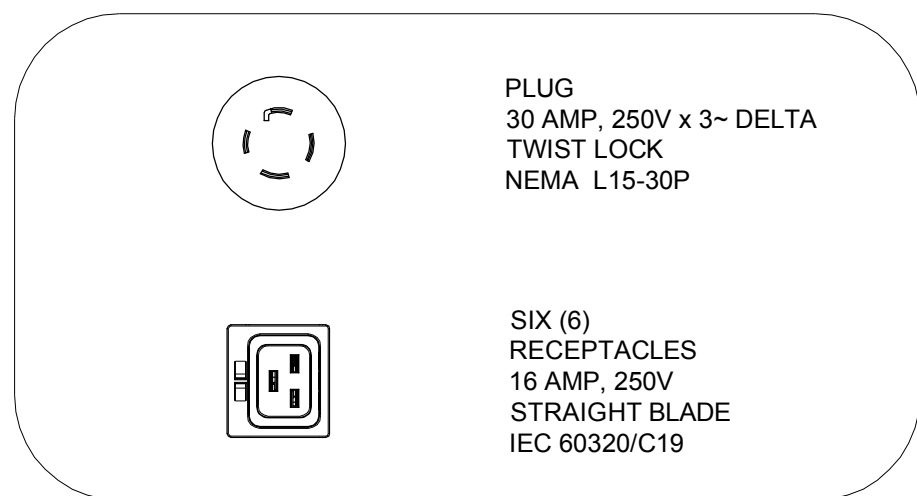

REV	DATE	BY	CHK	APR	DESCRIPTION	ECN
01A	09/21/2017	WSJ	MIM	EDM	INITIAL RELEASE	P06D16M

WE ASK THAT YOU CHECK FULLY THE DIMENSIONS, NOTES, AND SIGN THE CLIENT SIGNATURE BOX. THE JOB WILL NOT PROGRESS WITHOUT SIGNED APPROVAL. PLEASE DO NOT DELAY IN RETURNING PROOF AS IT WILL AFFECT DELIVERY		SIGN
		DATE
		PRINT
TITLE INTELLIGENT SERIES PDU P06D16M CUSTOMER DRAWING		
ITEM REVISION NAME		PANDUIT
DATASHEET FILE NAME:		
UNLESS OTHERWISE SPECIFIED DIMENSIONAL TOLERANCE ARE: mm [IN]		MATERIAL/COLOR: N/A
Tolerance(mm) 0<4.50 ±0.5 50<4.250 ±1.0 250<4.500 ±1.5 500<4.1000 ±2.5 1000<4.2000 ±4.0		DRAWING NUMBER: P06D16M_DC
THIRD ANGLE PROJECTION	DRAWN BY: WSJ DATE: 09/21/2017	SCALE: NONE SHT 1 OF 1